

# ND450

# Automatic Solder Printer

# User Manual

---



Applicable Model: ND450 Automatic Solder Printer.....

Version: V1.0.....

# Table of Contents

1. Preface .....	2
2. Precautions Before Using the Equipment .....	2
2.1. Important Precautions .....	6
2.2. Equipment Dimension Description .....	8
2.3. Introduction to Work Area Structure .....	8
2.4. Introduction to Equipment Structure .....	10
2.5. Operation Flow Chart .....	11
3. Introduction to Software Main Interface .....	12
3.1. Machine Homing .....	13
3.2. Open File .....	13
3.3. Edit File .....	14
3.3.1. Board Entry Parameter Editing .....	14
3.3.2. Adjustment Parameter Settings .....	17
3.3.3. Cleaning Parameter Settings .....	18
3.3.4. Printing Parameter Settings .....	19
3.4. Production Settings .....	20
3.5. Parameter Settings .....	21
3.6. Platform Movement .....	22
3.7. Manual Operation .....	23
4. Troubleshooting .....	24
5. Equipment Maintenance .....	25
5.1. Formulate Effective Measures to Reduce or Avoid Failures .....	25
5.1.1. Strengthen Daily Maintenance of the Machine .....	25
5.1.2. Requirements for Equipment Operators .....	25
5.1.3. Formulate Measures to Reduce or Avoid Errors .....	25
5.2. Solder Printer Maintenance .....	26
5.2.1. Daily Inspection Items .....	26
5.2.2. Monthly Inspection Items .....	27

# 1. Preface

Sincerely thank your company for choosing our equipment. This equipment is designed and configured according to the following purpose: to print the material on the stencil onto the board on the track. Please do not apply this equipment to other purposes other than the original purpose.

## 2. Precautions Before Using the Equipment

### **Important Notice to Users:**

Before operating this equipment, please read this manual and understand its contents. Please keep this manual in a place near the equipment for reference when needed.

Those who have not received training on this equipment shall not use it. When inspecting the equipment, replacing or repairing parts, or performing internal settings, please turn off the power switch.

Repair and maintenance operations not mentioned in this manual should be performed by our company's certified maintenance engineers. Customers shall not perform such operations based on their own judgment; otherwise, accidents may occur. It is prohibited for two or more people to operate the same machine simultaneously, and strictly forbidden for anyone to operate the machine with their head or hands inserted into it.



### **Removal of Anti-Rust Protective Film:**

To prevent rust caused by environmental influences during transportation, we have attached protective films to the following parts of the machine for protection (as shown in the figure below C). These protective films need to be manually removed before powering on the equipment. If omitted, there is a possibility of causing operational issues and damage.



### **Removal of Auxiliary Fixings for Transportation:**

To prevent component shaking during transportation from causing equipment damage, we have added auxiliary fixings to the following parts of the machine to prevent component shaking (as shown in the figure below A-B). These auxiliary fixings need to be manually removed before powering on the equipment. If omitted, there is a possibility of causing operational issues and damage.



### **Installation of Alarm Light:**

To prevent the alarm light from being damaged during transportation, the alarm light needs to be installed after arrival. The installation process refers to the figures below E1, E2, E3, E4



**Removal of Auxiliary Fixings for Transportation:**

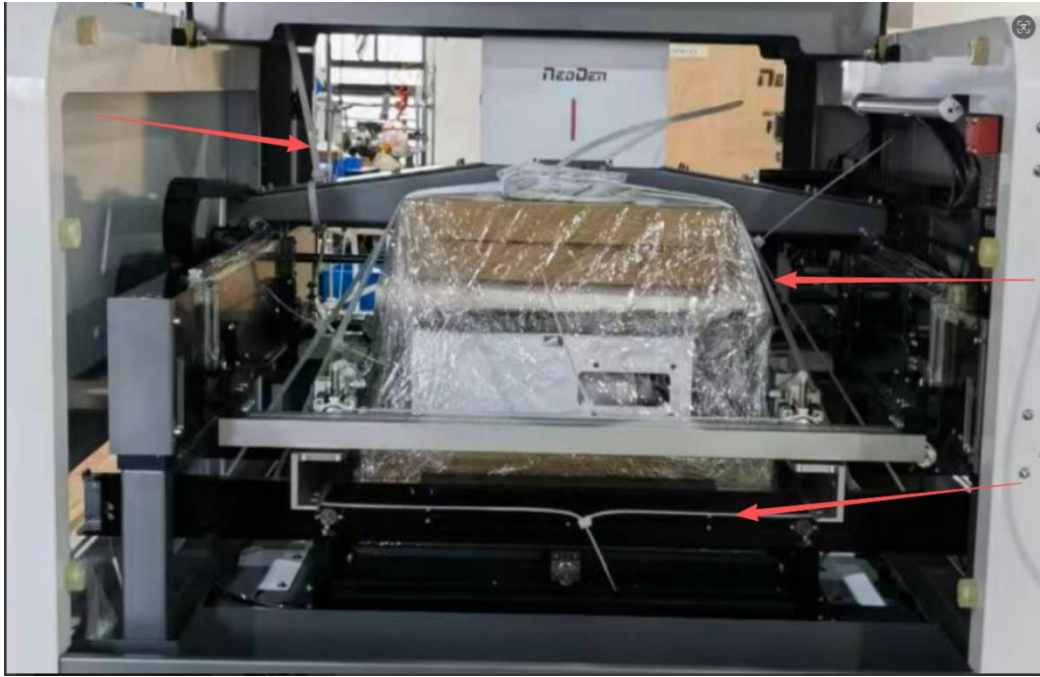

Figure A: Auxiliary Fixing Strap

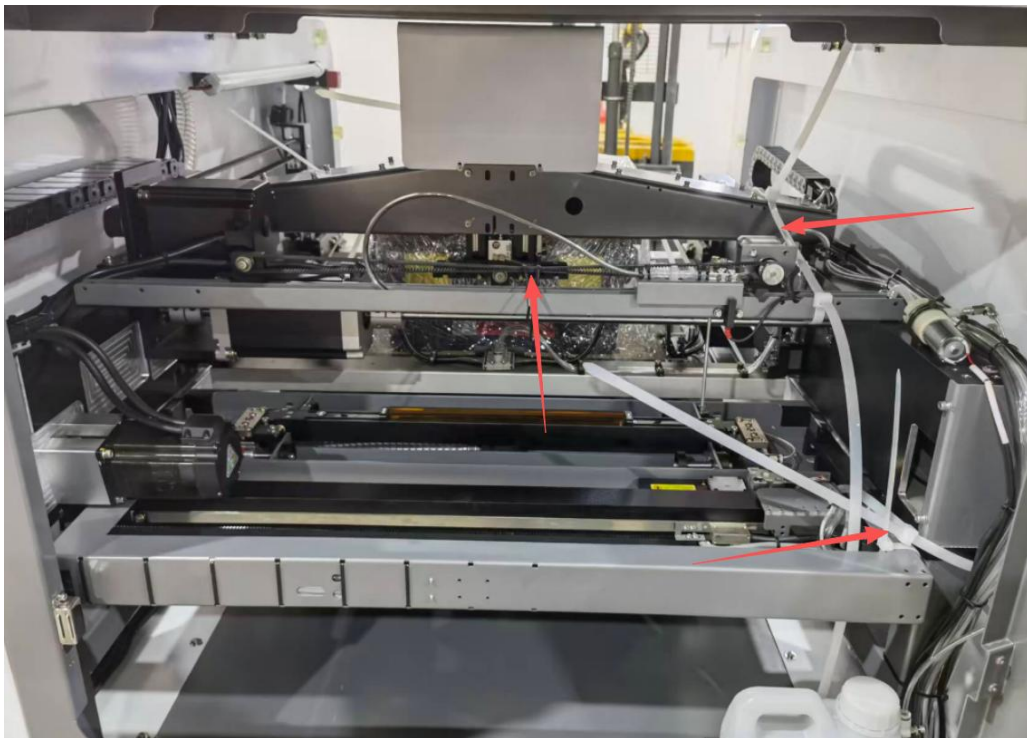

Figure B: Auxiliary Fixing Strap

**Removal of Anti-Rust Protective Film:**



Figure C: Protective Film

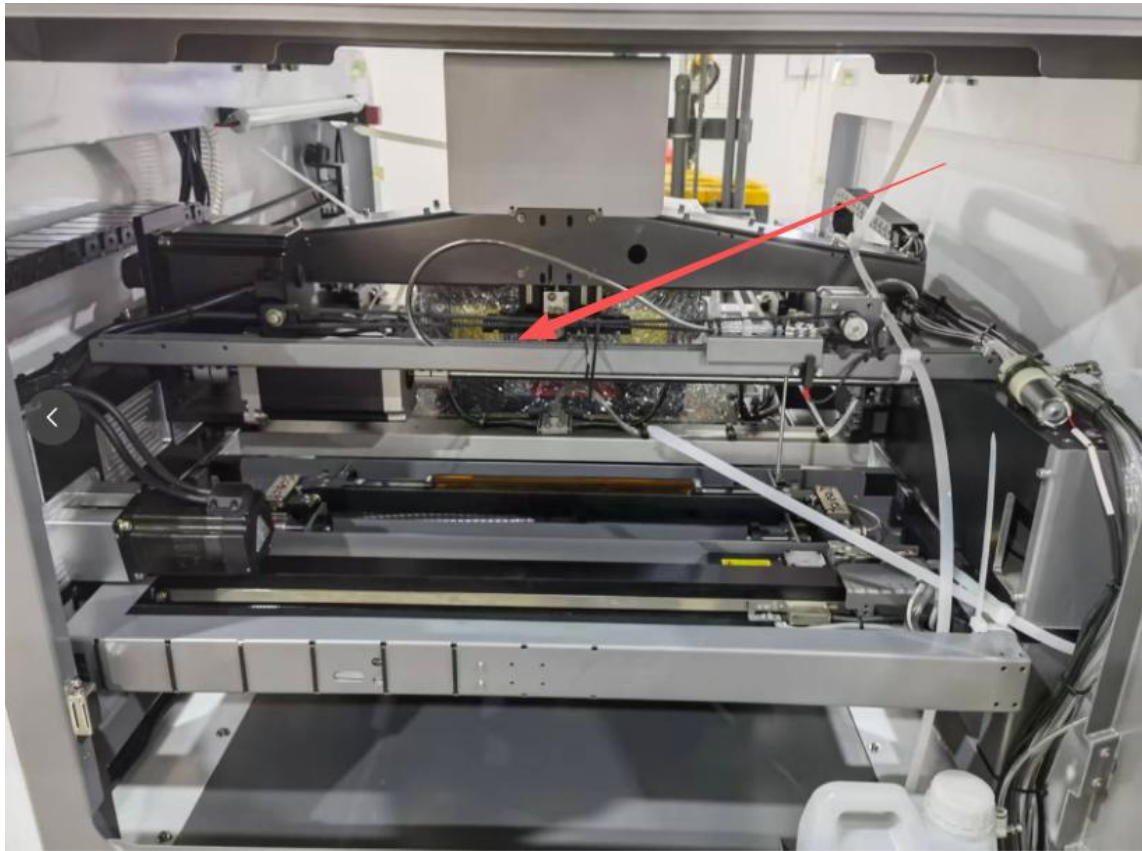

Figure D: Protective Film

## Installation of Alarm Light:



Figure E1: Step 1: Insert the wire into the hole



Figure E2: Step 2: Tighten the lamp

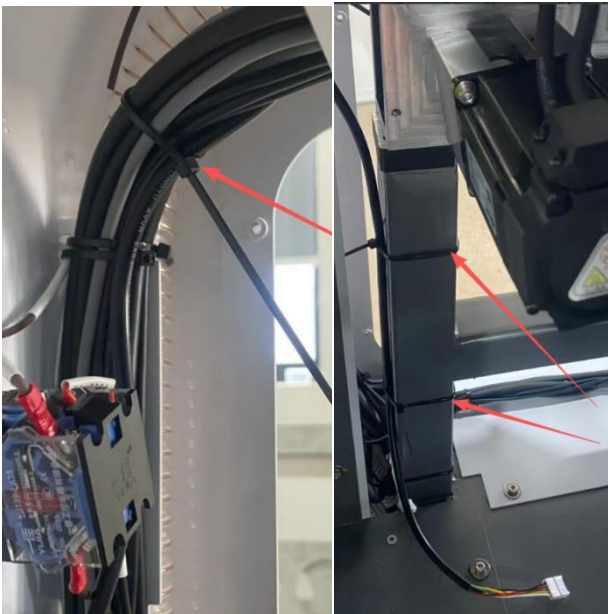

Figure E3: Step 3: Tie the wire with a strap and cut off the strap end

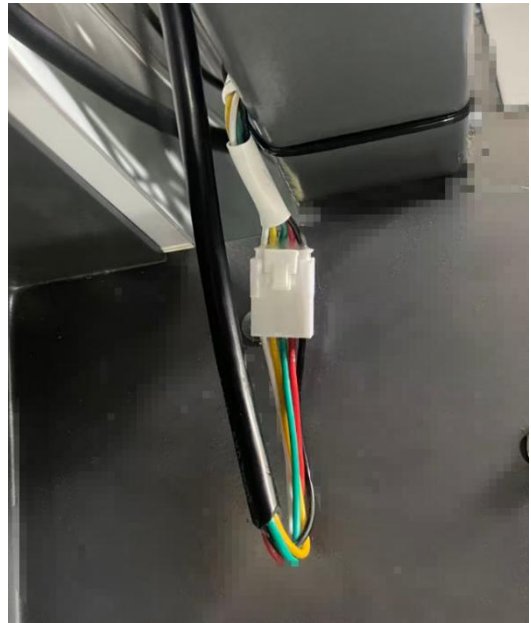

Figure E4: Step 4: Plug in the connector

## 2.1. Important Precautions



**Camera Recognition Failure Risk Warning:**

**No Touching or Impacting**

Mark Camera

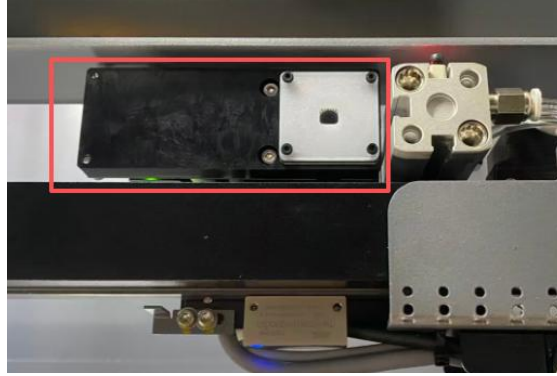

**Accuracy Failure Risk Warning, Magnetic materials are prohibited from approaching the magnetic grating scale.**

X-axis Magnetic Grating

Scale



Y-axis Magnetic Grating Scale

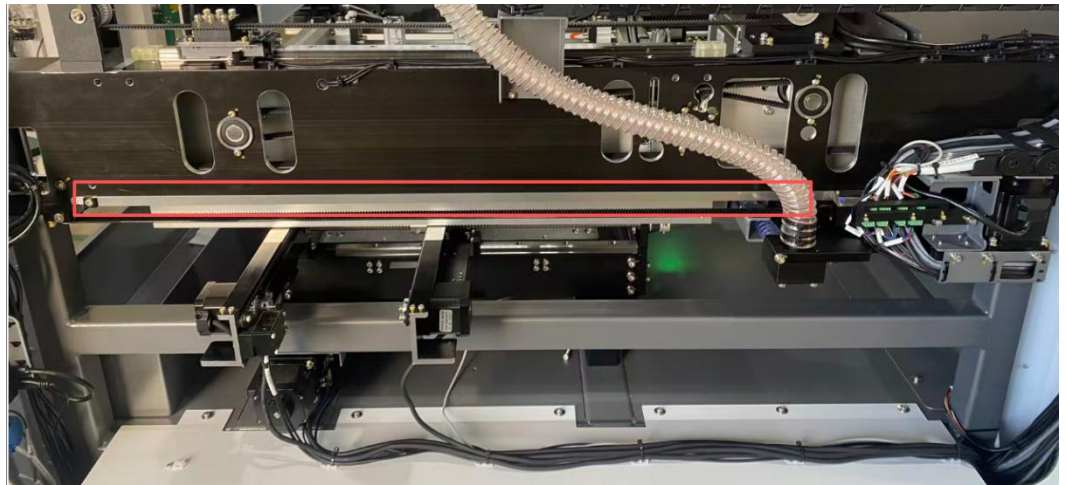



### **Electric Shock Risk Warning:**

You must operate in accordance with the following requirements: Connect input power that meets the equipment's requirements, and the machine's ground electrical interface must be effectively grounded. At any time when entering the chassis and pick head for maintenance operations, you must first shut down correctly and cut off the power supply.

### **Electric Shock and Abnormal Operation Risk Warning: You must operate in accordance with the following requirements:**

Illustration: Oil-Water Separator, Two-Piece Unit

1. The equipment air source connection pressure shall not be lower than 0.6 MPa.
2. Adjust the pressure to approximately 0.55 MPa. When adjusting the pressure, pull up the knob first before rotating it; pressing down the rotating knob locks the position. The pressure should be adjusted gradually and evenly to the required value, not in one step. From a top-down perspective, clockwise rotation increases the machine's air pressure, while counterclockwise decreases it.
3. The machine's inlet and outlet pipes must be connected according to the drawing; otherwise, water from the two-piece unit will drain into the machine, which may cause short circuits and electric shock issues. (1 is the intake pipe; 2 is the drain pipe)



## 2.2. Equipment Dimension Description

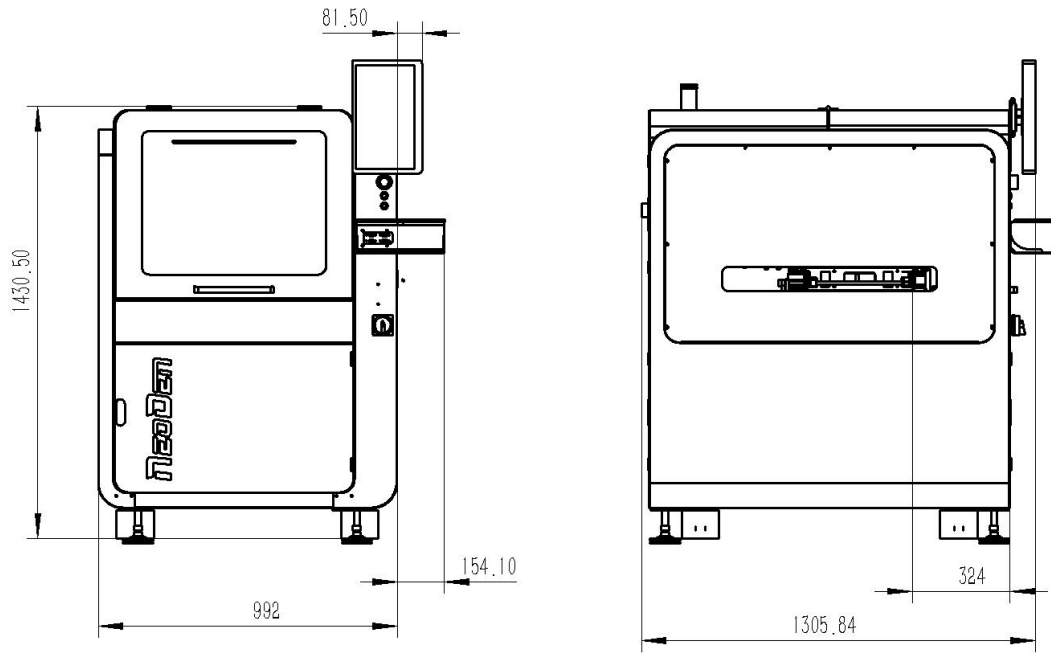
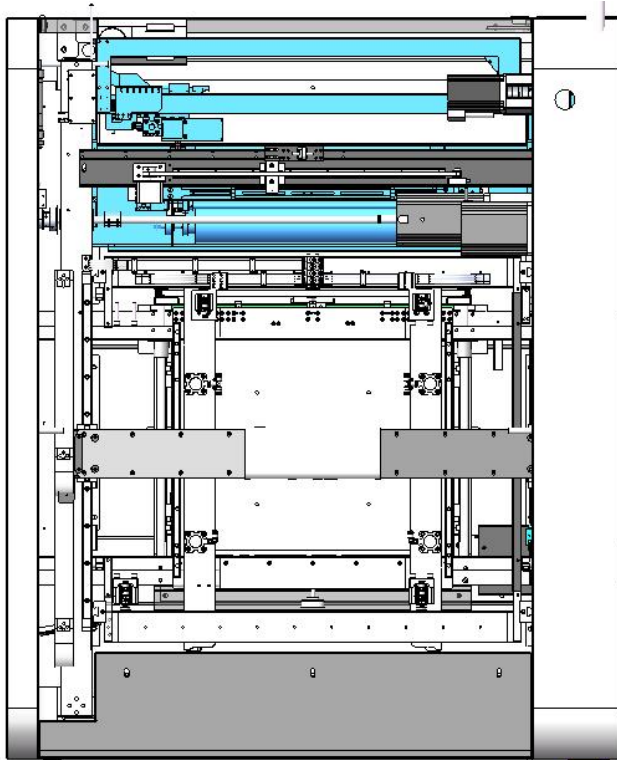
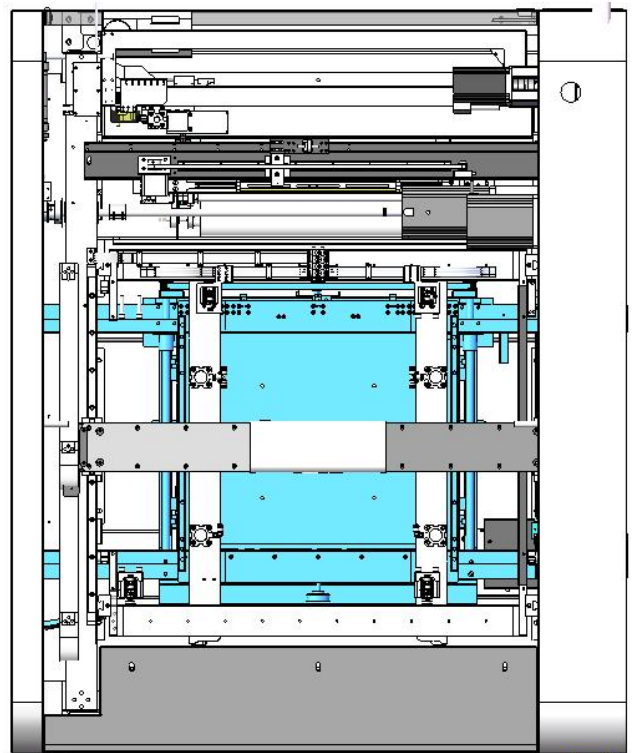

Figure 1: Equipment Dimension Diagram

## 2.3. Introduction to Work Area Structure



Camera and Cleaning Module



Track Module

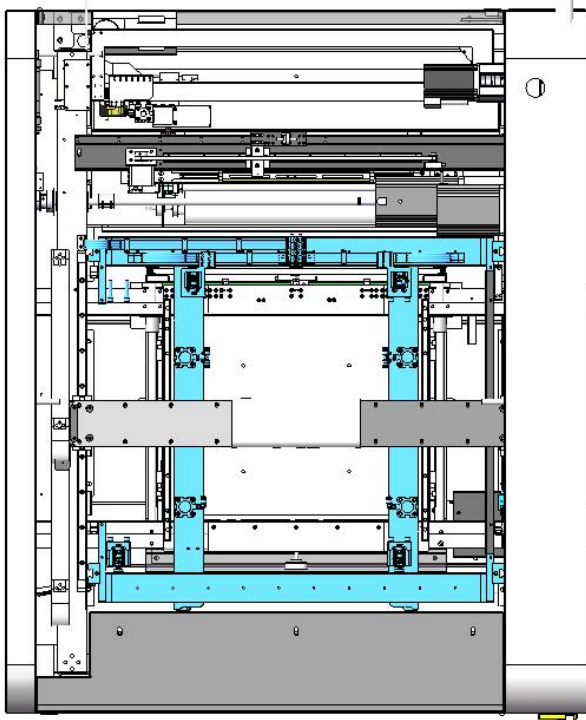

Stencil Fixing Module

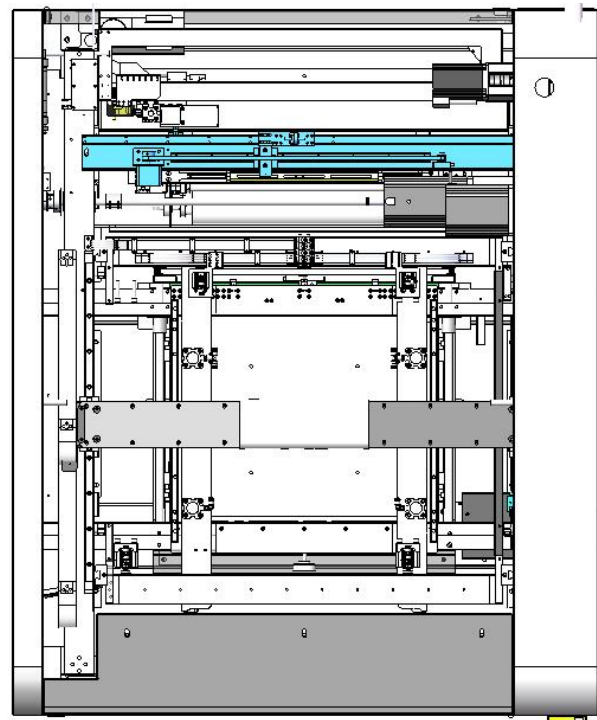

Spray Module

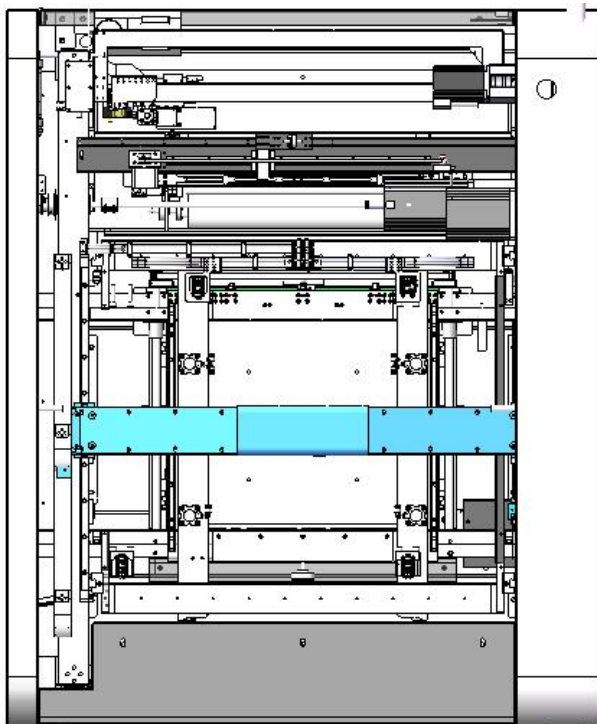

Squeegee Crossbeam Module

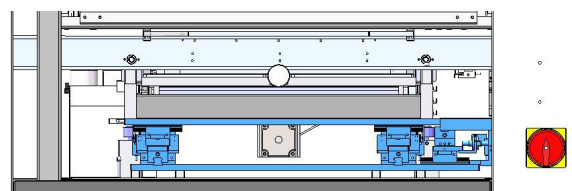

Track Platform Adjustment Module

## 2.4. Introduction to Equipment Structure

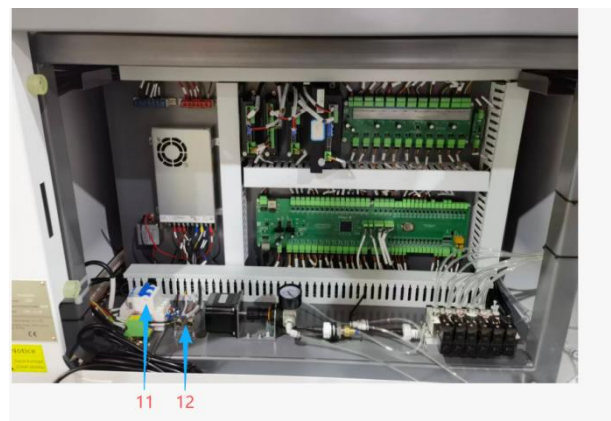
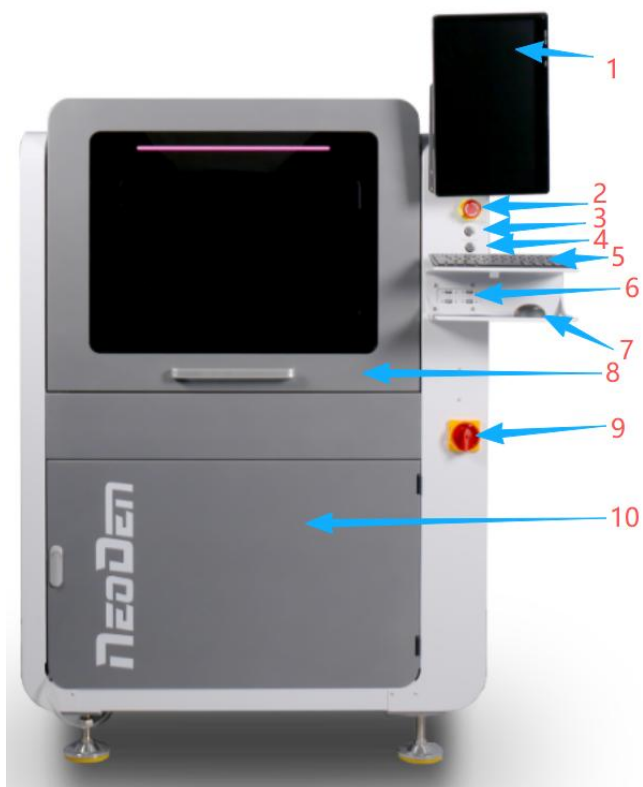

(1) Display Screen

(2) Emergency Stop

(3) Start/Stop Switch

(4) Reset Switch

(5) Keyboard

(11) Machine Power Air Switch

(6) USB Port

(7) Mouse

(8) Cover Door

(9) Power Switch

(10) Front Cover Door (Oil-Water Separator Two-Piece Unit)

(12) Front/Rear Connection Table Jack

## 2.5. Operation Flow Chart

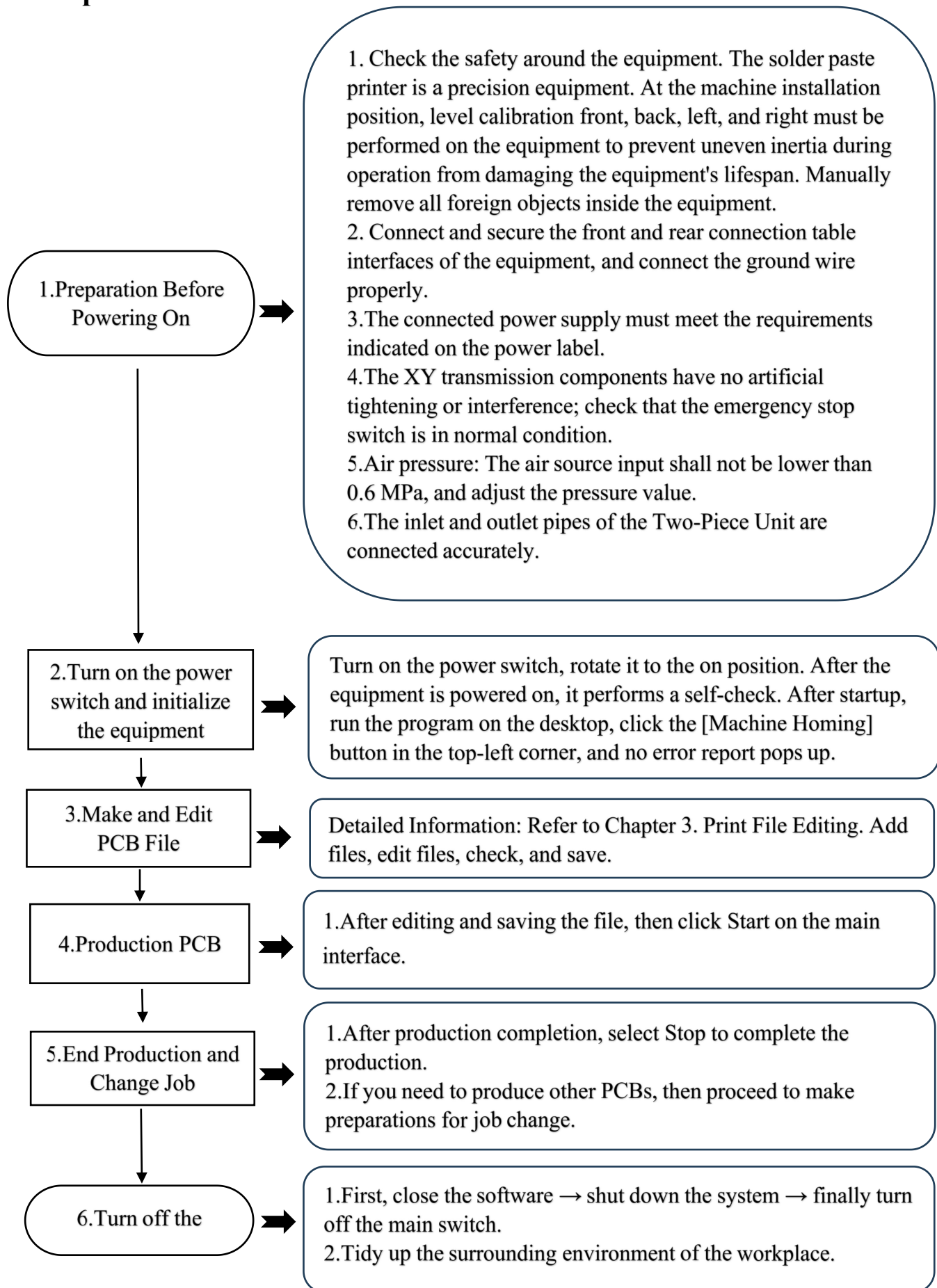

# 3. Introduction to Software Main Interface

[Machine and File Parameter Settings]

[Production Part Parameter Display] Area

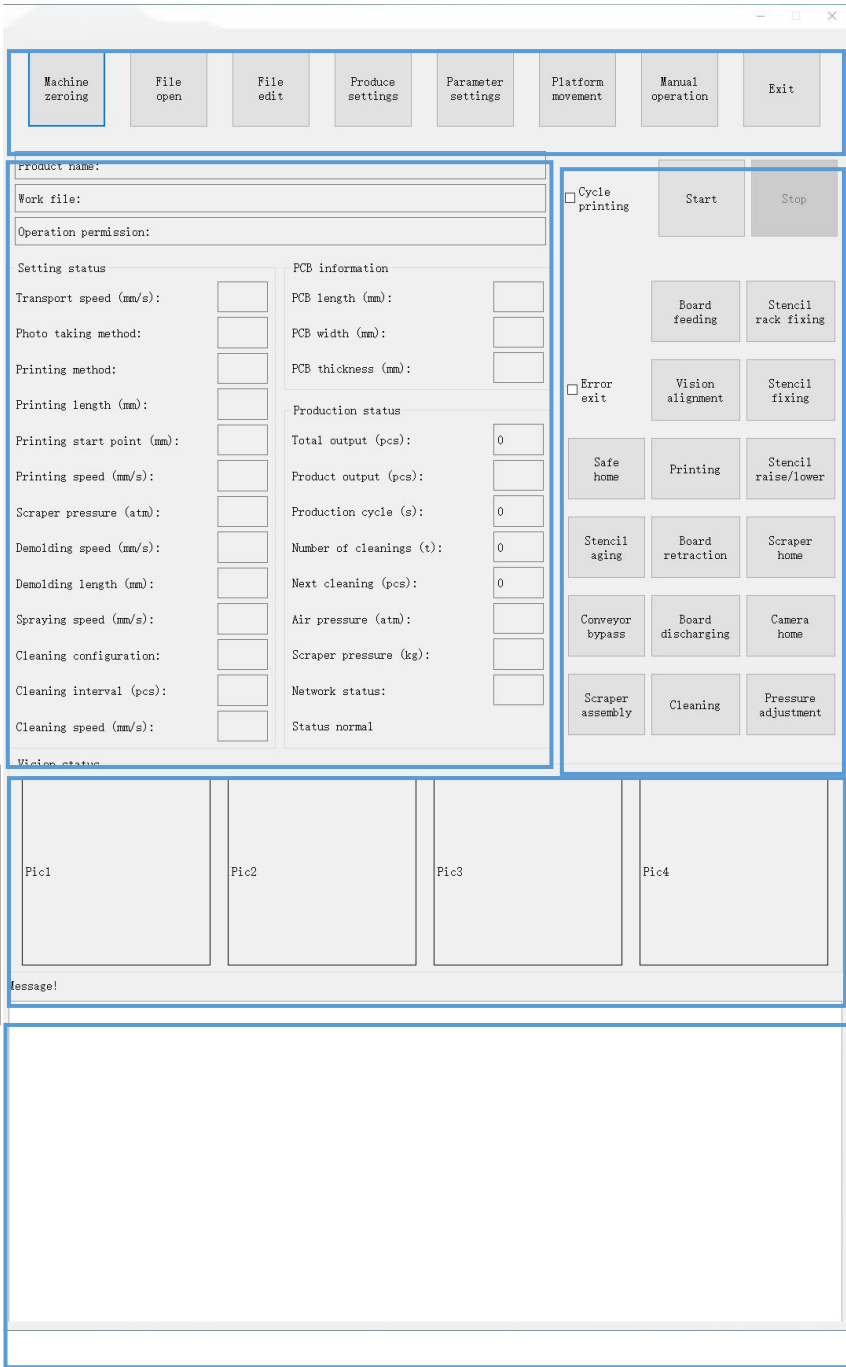

Machine Operation Buttons  
 Cycle Printing: If not checked, will not print continuously.

Vision status  
 Pic1:PCB Mark1  
 Pic2:Stencil Mark1  
 Pic3:PCB Mark2  
 Pic4:Stencil Mark2

Platform Adjustment Data Display

### 3.1. Machine Homing

The first step after the machine is powered on. After clicking  , the machine will home all motion axes to the zero point, and the track width will be automatically recognized.

### 3.2. Open File

To add or edit, you must first click this button  . After clicking, the window below will pop up.

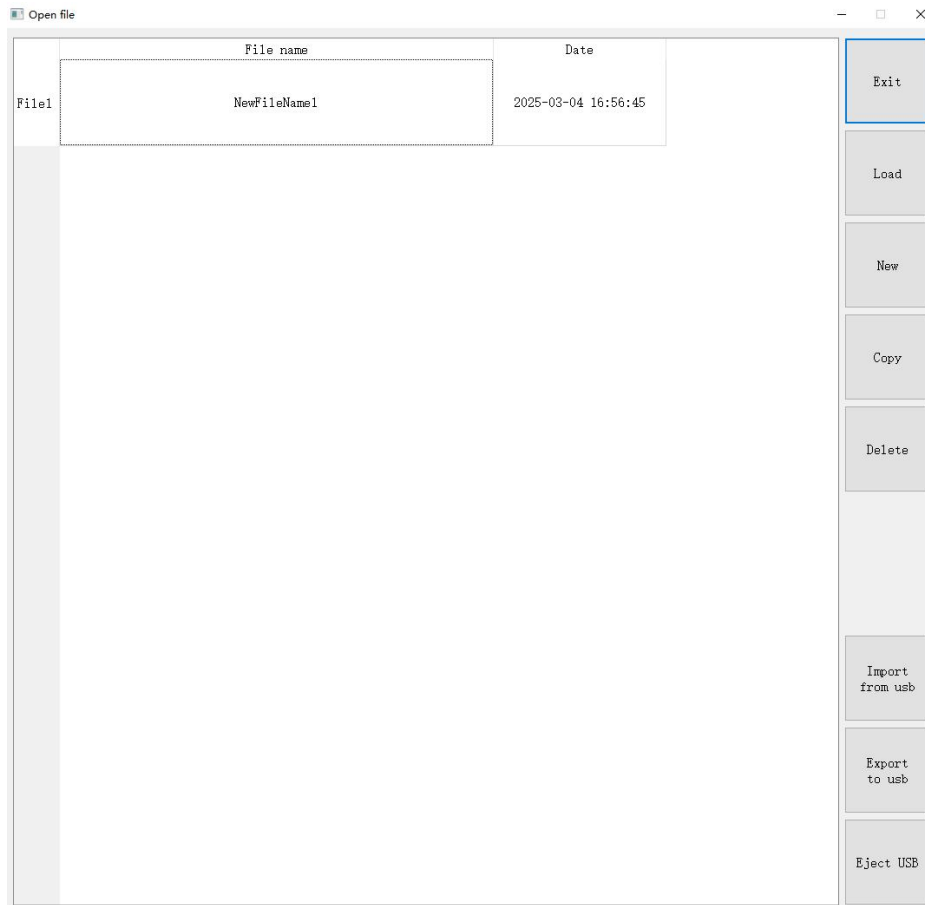

#### Button Function Description:

Exit: Exit this window.

Load: Select the file to be produced, then click this button, and then exit this window

New: Add a new production file.

Copy: After selecting a file, click this button to add a duplicate production file.

Delete: Select a file and click this button to delete it.

Import from USB: Load the file from the U disk.

Export to U USB: Select a file and click this button to export it to the U disk.

Eject USB: Click this button before unplugging the U disk.

### 3.3. Edit File



Edit the loaded file. After clicking , the window below will pop up.

#### 3.3.1. Board Entry Parameter Editing

Click the "Concise" button to display all editing parameters.

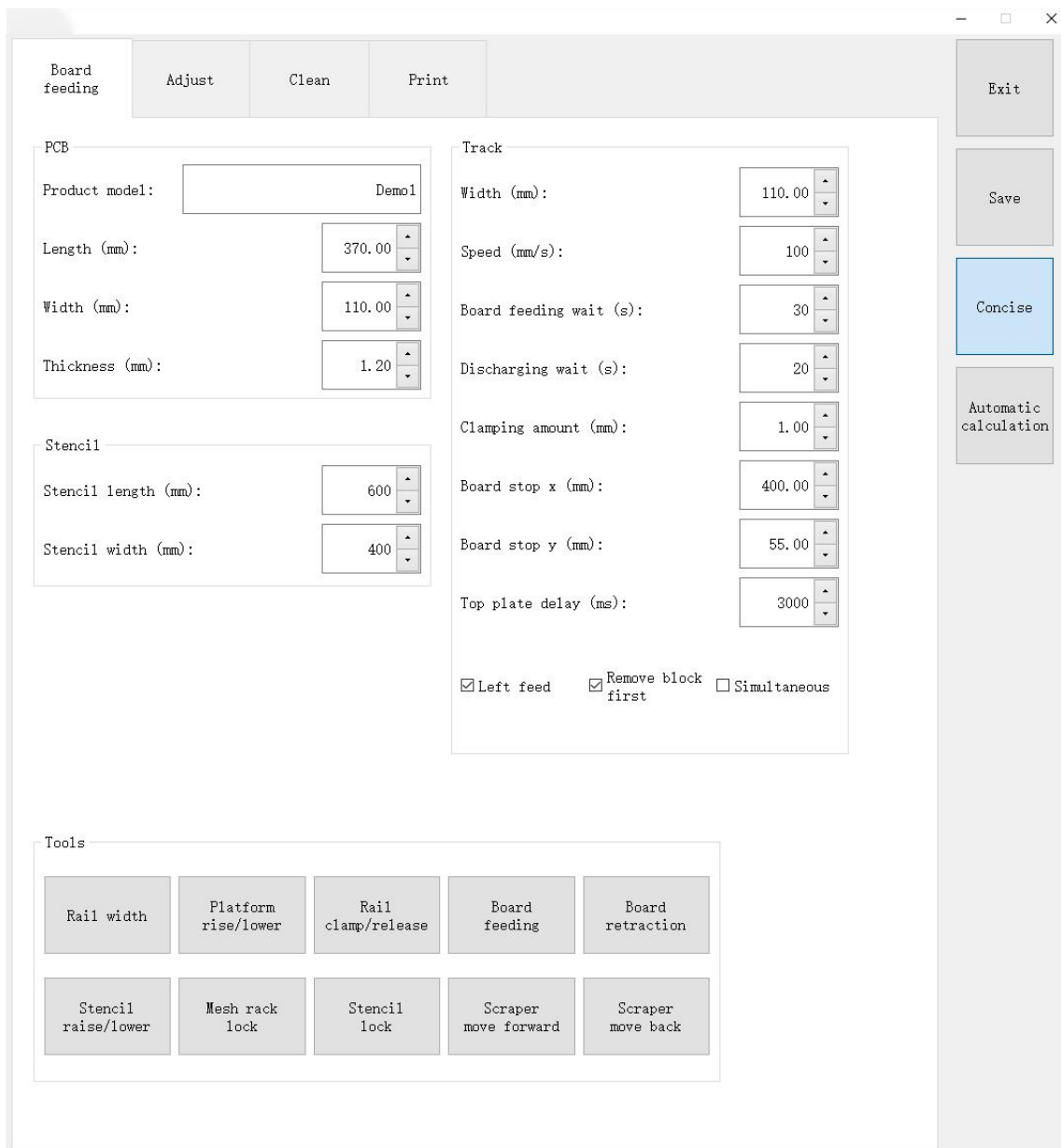

Editing Steps:

1. Output accurate PCB and stencil dimensions, then click [Save]
2. Click [Auto Calculation].

3. Click [Rail Width].
4. Place the PCB thimble block (for reference).
5. Place the PCB on the track. If the track width is inappropriate, adjust the track width parameter, then click [Save], and then click [Rail Width].
6. Click [Platform rise/lower] to confirm the platform is lifted. Adjust the "Platform Adjustment Knob" to make the upper surface of the PCB and the upper surface of the "PCB Clamp" level (allow slight protrusion).
7. Click [Rail clamp/release] to confirm if the board is clamped. The clamping amount can be adjusted based on actual conditions.
8. Take out the board and place it at the track entrance, then click [Board Feeding].
9. Click [Mesh rack lock] and [Stencil Lock], then move the stencil fixing crossbeam to the outermost edge.
10. Click [Stencil raise/lower], then manually place the stencil and roughly align it with the PCB.
11. Move the "stencil fixing crossbeam" to clamp the stencil, then click [Mesh rack lock] and [Stencil Lock], and manually check if the stencil is fully fixed.
12. Click [Stencil raise/lower] to ensure the stencil rises to the highest point.

## Thimble Block Arrangement

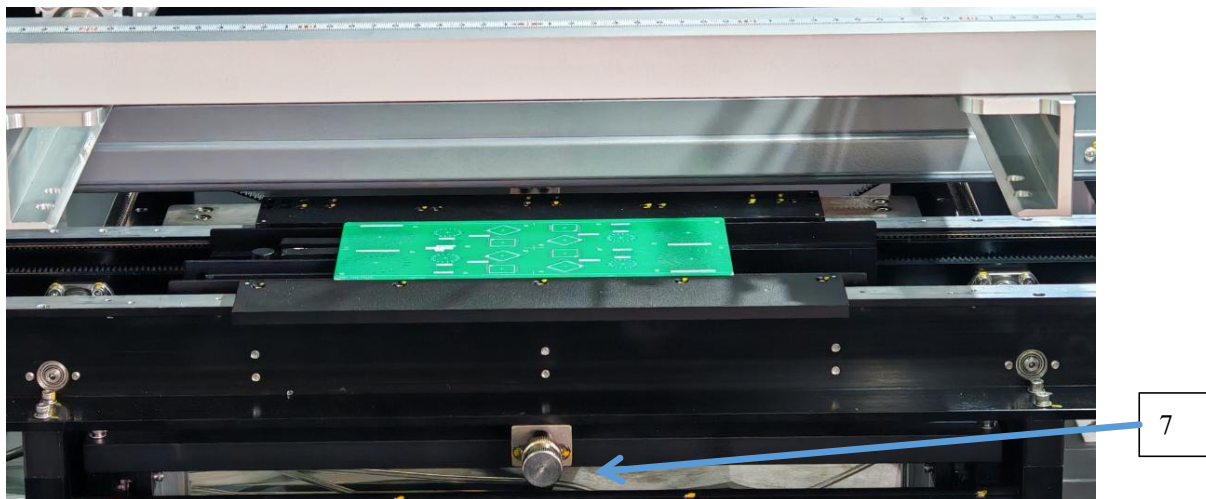
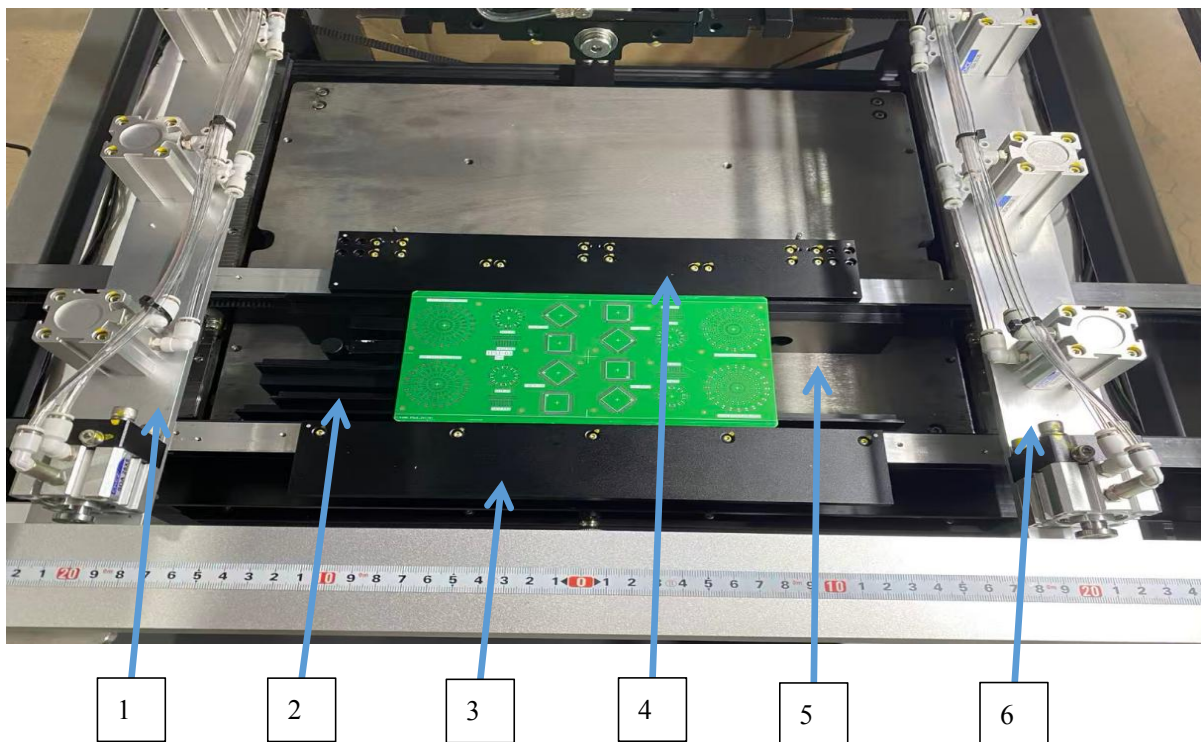

1. Stencil fixing crossbeam   2. PCB thimble block   3. PCB Clamp   4. PCB Clamp  
 4. PCB thimble block   6. stencil fixing crossbeam   7. Platform Adjustment Knob

Note: 1. The stencil fixing crossbeam cannot be directly above the PCB thimble block; otherwise, when the stencil descends, it will squeeze with the thimble block and damage the components.

2. The middle thimble block should be placed after successful board entry. The middle thimble block should not exceed the board; otherwise, it will interfere with the stop pin and easily damage the components.

### 3.3.2.Adjustment Parameter Settings

#### Operation Steps:

1. Lock the alignment points of Mark1 and Mark2. For convenience, you can first click the four corners, then make the selection.
2. If there are similar points around the mark point, you can reduce the recognition range.
3. When locking, the upper left corner of the image shows roundness and diameter, which can be used as a reference for setting "Upper left", "Upper right", and "Roundness".
4. When both the stencil and PCB have mark points, you can choose dual shot. If the stencil has no mark points, you can choose single shot.
5. If the initial alignment distance between the stencil and PCB is too large, you can increase the error tolerance.
6. The highest precision can be set according to error requirements. The recommended number of adjustments is 5.
7. If each printing offset is consistent, you can change the manual offset parameters.
8. Click [Save]

### 3.3.3 Cleaning Parameter Settings

The screenshot shows a software window titled "Cleaning Parameter Settings" with a standard Windows-style title bar (minimize, maximize, close). The window is divided into several functional areas:

- Top Navigation:** A horizontal bar with buttons for "Board feeding", "Adjust", "Clean" (highlighted), and "Print".
- Right Sidebar:** A vertical column of buttons: "Exit", "Save", "Concise" (highlighted in blue), and "Automatic calculation".
- Clean Section (Left):**
  - Automatic cleaning interval (pcs): 5
  - Cleaning starting point (mm): 0
  - Cleaning length (mm): 100
  - Buttons: "Cleaning starting point" and "Cleaning end point"
  - Manual cleaning interval (pcs): 0
- Spray Section (Left):**
  - Spray starting point (mm): 20
  - Spray stroke (mm): 220
  - Spray speed (mm/s): 200
  - Buttons: "Go to spray Starting point" and "Go to spray end point"
- Cleaning details Section (Right):**
  - Wet: 1
  - Vacuum cleaning: 1
  - Empty: 0
  - Empty: 0
  - Cleaning speed (mm/s): 50
  - Vacuum suction delay (ms): 500
  - Cleaning liquid delay (ms): 99
  - Cleaning paper (mm): 5.00
  - Cleaning after standby timeout
  - From back to front
  - Standby time (min): 20
  - Paper detection
  - Button: "Paper feeding"

#### Operation Steps:

1. Set the cleaning start and end points. You can click [Cleaning Starting Point] and [Cleaning End Point] to check.
2. [Cleaning paper] recommend: 15
3. Click [Save]

### 3.3.4 Printing Parameter Settings

The screenshot shows a software interface for printing parameter settings. At the top, there are tabs for 'Board feeding', 'Adjust', 'Clean', 'Print', and 'Exit'. The 'Print' tab is active. The interface is divided into two main sections: 'Print' and 'Demoulding'. The 'Print' section contains the following parameters:

- Printing speed (mm/s): 50
- Scraper pressure (kg): 3.00
- Printing method: Front brus
- Starting point offset (mm): 0
- Printing starting point (mm): -33
- Printing length (mm): 100
- Tin addition reminder (pcs): 100

The 'Demoulding' section contains the following parameters:

- Demoulding length (mm): 4.00
- Demoulding speed (mm/s): 1.00
- Pause time before demoulding(ms): 200
- Pause time after demoulding(ms): 200

There are also buttons for 'Starting point' and 'End point' in the 'Print' section, and 'Concise' and 'Automatic calculation' in the right sidebar. The 'Concise' button is highlighted in blue.

#### Operation Steps:

1. Printing Speed: Recommend 10.
2. Set the printing start and end points to ensure that the front and rear squeegees can completely scrape the stencil holes and then run an extra 10mm or so.
3. After setting the Demolding length, observe the actual demolding situation and modify appropriately.
4. If the solder paste is too active, increase the [Pausing Time Before Demolding]; recommended time: 1000-2000.
5. [Pausing Time Before Demolding] recommended: 1000-3000.
6. Click [Save].

### 3.4. Production Settings

Edit the Production settings. After clicking  , the window below will pop up.

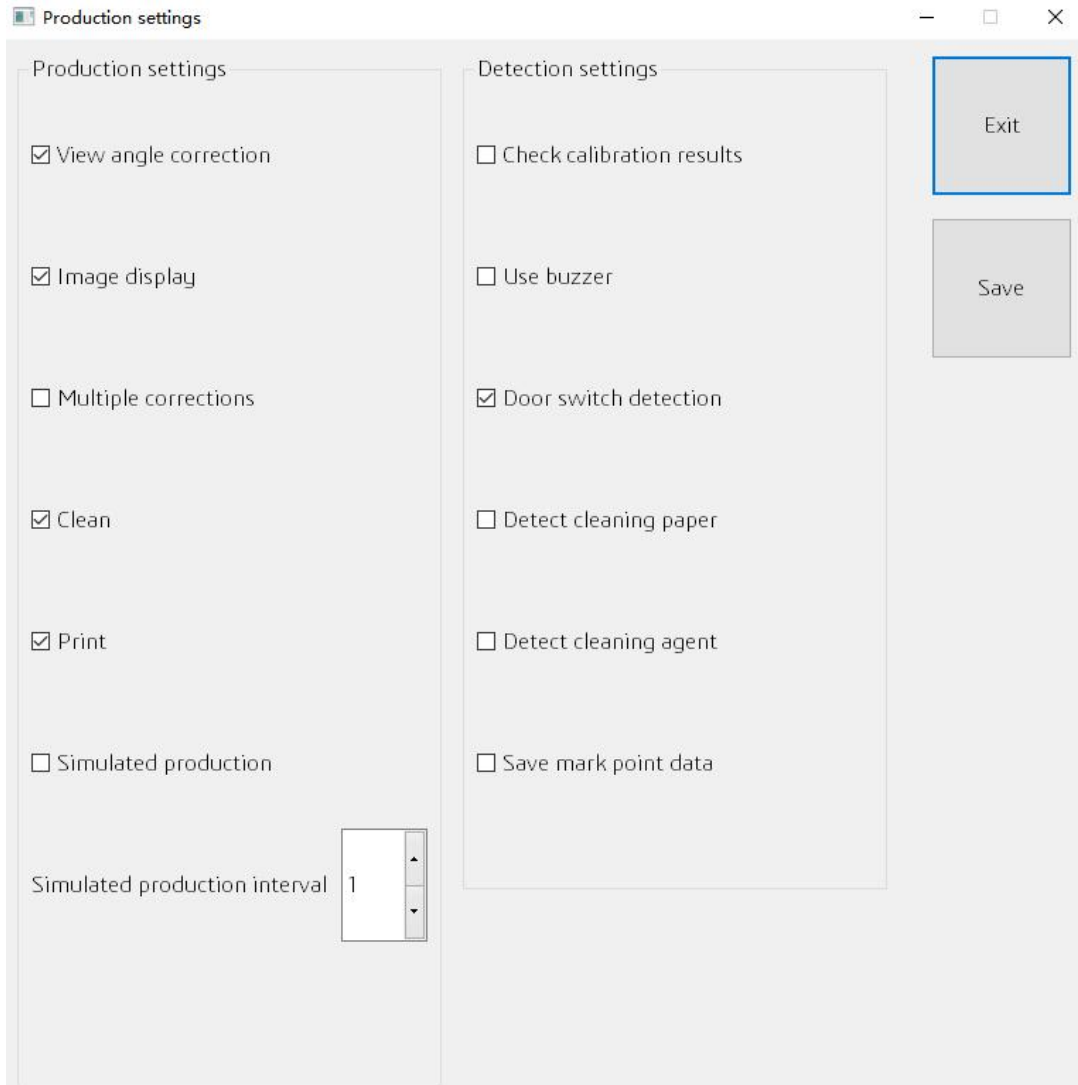

Set Referring to the picture above. After checking the [Simulated Production] box, the machine will not print the soldering paste.

## 3.5. Parameter Settings

Edit the Parameter settings. After clicking , the window below will pop up.

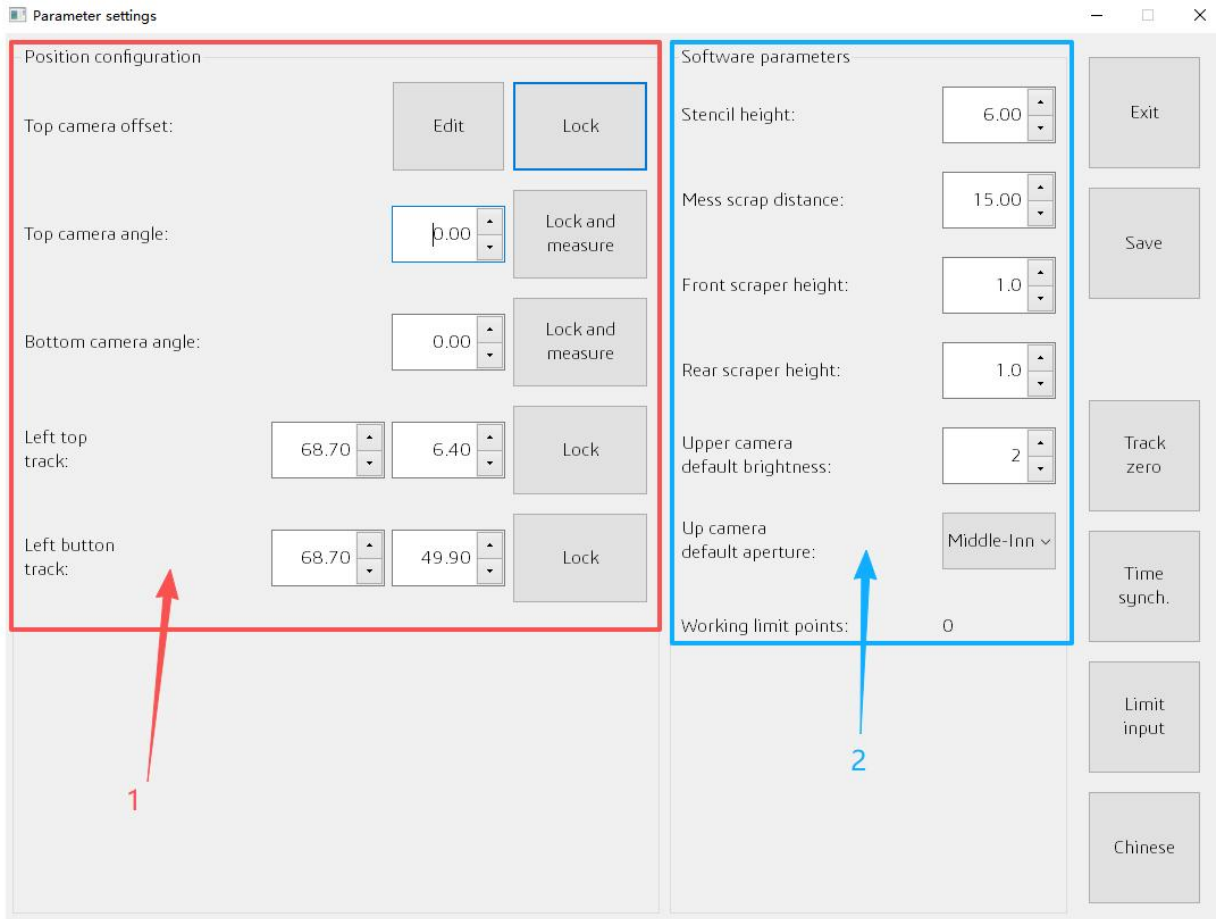

Parameters in Part 1 **cannot be** modified by yourself.

Explanation of parameters in Part 2:

**Stencil Height:** Stencil lowering position. The smaller the value, the lower the stencil.

**Mess scrap distance**(Stencil-to-Squeegee Distance): Distance between the squeegee and the stencil surface before printing.

**Front scraper height:** Height of the near squeegee during printing (If squeegee height is standard, no need to set).

**Rear Squeegee Height:** Height of the far squeegee during printing (If squeegee height is standard, no need to set).

**Upper Camera Default Brightness:** If the photo brightness of the stencil's Mark points is too dark or too bright, this value can be adjusted.

**Upper Camera Default Aperture:** Set according to the photo effect of the stencil's Mark points.

### 3.6. Platform Movement



Edit the Platform Movement. After clicking , the window below will pop up.

Function:

1. Move the camera to observe the alignment between the PCB and the stencil.
2. In the Platform Movement Window, the parameter to be enter here is the movement distance per click (movement of the entire track platform).

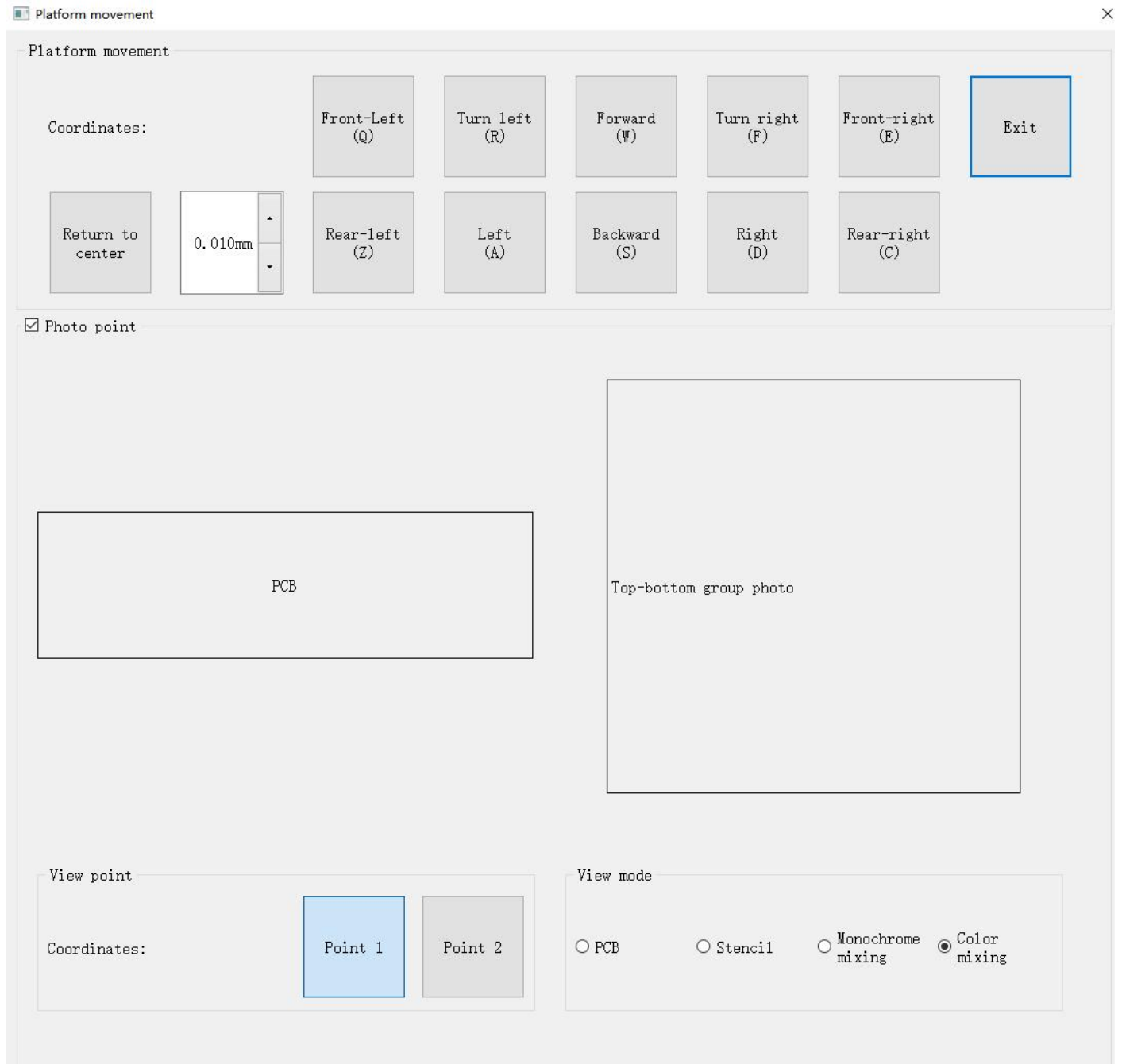

### 3.7. Manual Operation

Manual operation

After clicking [Manual operation](#), the window below will pop up. It's to manually operate the movement of each axis and solenoid valve.

Manual operation

Basic iO Motor Camera Log Exit

Take photo

CB mark loc

sencil mark loc

Aperture:  Outer  Middle  Inner Brightness: 3

Move by coordinates

0.00 0.00 Move to target

Movement mode

Continuous mo 20mm

Jog distance 0.10mm

Directional movement

Front

Left Rear Right

## 4. Troubleshooting

<b>Problem</b>	<b>Possible Causes</b>	<b>Corresponding Measures</b>
Raspberry Pi cannot enter the system after powering on	<ol style="list-style-type: none"> <li>1. SD card is loose</li> <li>2. SD card is damaged</li> </ol>	<ol style="list-style-type: none"> <li>1. Reinsert the SD card</li> <li>2. Use a spare SD card</li> </ol>
Top plate abnormality	<ol style="list-style-type: none"> <li>1. Solenoid valve is broken</li> <li>2. Air tube leaks</li> </ol>	<ol style="list-style-type: none"> <li>1. If swapping the feeder solenoid valve changes the phenomenon, replace the feeder solenoid valve</li> <li>2. Replace the air tube or reinsert it</li> </ol>
Clamp abnormality	<ol style="list-style-type: none"> <li>1. Clamp parameters are set unreasonably</li> </ol>	<ol style="list-style-type: none"> <li>1. Adjust the clamp parameters</li> </ol>
Mark Camera cannot take photos	<ol style="list-style-type: none"> <li>1. Software code exception</li> <li>2. Internal board of the camera is broken</li> <li>3. Poor contact of the camera's network cable</li> </ol>	<ol style="list-style-type: none"> <li>1. Try again; if not, power off and restart</li> <li>2. Provide relevant videos for replacement</li> <li>3. Contact our after-sales service</li> </ol>
All axes cannot move	<ol style="list-style-type: none"> <li>1. Software code exception</li> <li>2. Main control board is damaged</li> </ol>	<ol style="list-style-type: none"> <li>1. Try again; if not, power off and restart</li> <li>2. Provide relevant videos for replacement; Contact our after-sales service</li> </ol>
Accuracy issue	<ol style="list-style-type: none"> <li>1. Edit File - Adjustment - Maximum precision setting is too high</li> <li>2. Stencil is loose</li> </ol>	<ol style="list-style-type: none"> <li>1. Reduce the accuracy value</li> <li>2. Check if the stencil is clamped and check the air pressure</li> </ol>
Cannot find Mark points, prompt indicates Mark point recognition failure	<ol style="list-style-type: none"> <li>1. Incomplete board entry</li> <li>2. Edit File - Adjustment - Lock, position setting is incorrect</li> <li>3. Cannot find Mark points, there are interference points</li> </ol>	<ol style="list-style-type: none"> <li>1. Check the track width and whether the board jams within the entire track. Reduce the parameter "File Edit - Board Entry - Track Speed"</li> <li>2. Relock after successful board entry</li> <li>3. Reset Mark point parameters</li> </ol>
Solder Paste Not Scraped Clean	<ol style="list-style-type: none"> <li>1. Squeegee pressure setting is too small.</li> <li>2. Did not click "Pressure Adjustment" on the main interface after setting the squeegee pressure.</li> <li>3. PCB is too soft or thimbles are improperly placed.</li> </ol>	<ol style="list-style-type: none"> <li>1. Reset the squeegee pressure.</li> <li>2. Click "Pressure Adjustment" on the main interface.</li> <li>3. Reposition the thimbles.</li> </ol>

# **5. Equipment Maintenance**

## **5.1. Formulate Effective Measures to Reduce or Avoid Failures**

### **5.1.1. Strengthen Daily Maintenance of the Machine**

The printer is a relatively complex, high-tech, and high-precision machine, requiring operation in an environment with constant temperature, humidity, and high cleanliness. Daily maintenance must be carried out by strictly adhering to the daily, weekly, monthly, semi-annual, and annual maintenance measures specified by the equipment.

### **5.1.2. Requirements for Equipment Operators**

Operators should receive certain SMT professional knowledge and technical training.

Operate the machine strictly in accordance with the operating procedures. It is not allowed to operate the equipment when it is faulty. In case of a fault, stop the machine immediately, report to the technical responsible person or equipment maintenance personnel, and use it only after the fault is eliminated.

Operators are required to concentrate during operation, being diligent in eyes, ears, and hands.

1. Eyes: Observe whether there are any abnormal phenomena during machine operation. For example, insufficient solder paste, machine error shutdown, excessive offset in sample printing, etc.
2. Ears: Listen for any abnormal sounds during machine operation. For example, abnormal sounds from platform adjustment, track, etc.
3. Hands: Solve abnormal phenomena in a timely manner. Some minor faults can be solved by operators themselves, such as the board falling under the track during board feeding.

### **5.1.3. Formulate Measures to Reduce or Avoid Errors**

During the printing process, the most common and frequent error is printing offset. Therefore, the following measures are formulated for prevention.

1. The parameters of Mark points for calibration should be set with reference to the upper left corner of the image.
2. The maximum precision setting must be accurate.
3. After the first print is completed, manually confirm the offset situation.

In summary, the printing speed and precision of the printer are fixed. How to give full play to the machine's due role depends largely on human factors. It is necessary to formulate practical and effective rules, regulations, and management measures to ensure the normal operation of the machine and guarantee printing quality and efficiency.

## 5.2.Solder Printer Maintenance

A regular inspection and maintenance system should be established.

### 5.2.1.Daily Inspection Items

	<b>Check the following items</b>
<p><b>Before turning on the power of the printer</b></p> <p><b>Inspect the following items</b></p>	<ol style="list-style-type: none"> <li>1. Temperature and Humidity: Temperature between 20°C ~ 26°C , humidity between 45% ~ 70%.</li> <li>2. Indoor Environment: Require clean air, free of corrosive gases.</li> <li>3. Ensure no useless junk on the transportation rail and within the moving range of the squeegee.</li> <li>4. Ensure no useless junk on the camera; check if the lens is clean.</li> <li>5. Ensure no useless junk on the thimble platform.</li> <li>6. Check if the clamp plate rebounds normally.</li> <li>7. Check the connection of air connectors, air tubes, etc.</li> <li>8. Check if the air pressure is up to the standard.</li> </ol>
<p><b>After turning on the power of the printer</b></p> <p><b>Inspect the following items</b></p>	<ol style="list-style-type: none"> <li>1. After starting the system, check if the machine homing is normal. When the rail automatically recognizes the width, check if the Mark point recognition on the rail is normal.</li> <li>2. Check if the emergency switch works properly.</li> <li>3. Check if the squeegee can correctly return to the starting point (origin).</li> <li>4. Check for abnormal noise when the squeegee moves.</li> <li>5. Check if the PCB runs smoothly on the rail; check if the sensor is sensitive.</li> </ol>

## 5.2.2.Monthly Inspection Items

<b>Inspection Item</b>	<b>Inspection Content</b>
X/Y Axis	When the camera moves, ensure the X/Y Axis has no abnormal noise.
X/Y Motor	Ensure the X/Y Motor has no abnormal heating.
Squeegee Fixing Base	Check if it can swing freely.
Air Duct	Check the connection between the duct and the machine. Ensure the Air Duct has no tears, wear, air leakage, etc.
Squeegee Cylinder	Check if the Squeegee Cylinder rebounds normally.
Lead Screw, Linear Guide	Check the Lead Screw and Linear Guide for dust, clean in time, and lubricate.
Operation Switch	Test if each push-button switch functions properly.
Connector	Check if the connections of air connectors, air ducts, etc. are good , and if there is any air leakage.
PCB Clamp Block	Check their wear condition.

Dear User!

The above contains the relevant content from the operation instructions for the ND450 model printer. For any matters not covered, please contact your account manager. We will serve you wholeheartedly. Finally, once again thank you for choosing our equipment.

Best regards.

Zhejiang NeoDen Technology Co., Ltd.